

REV.	DESCRIPTION	DATE
A	NEW DRAWING	7/30/2007

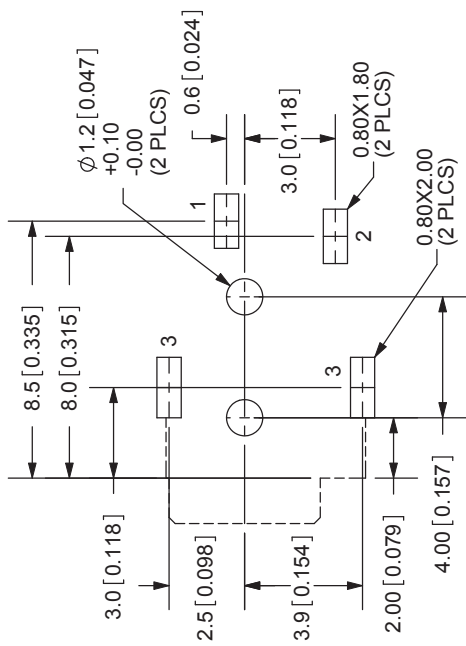

PCB LAYOUT
TOP VIEW

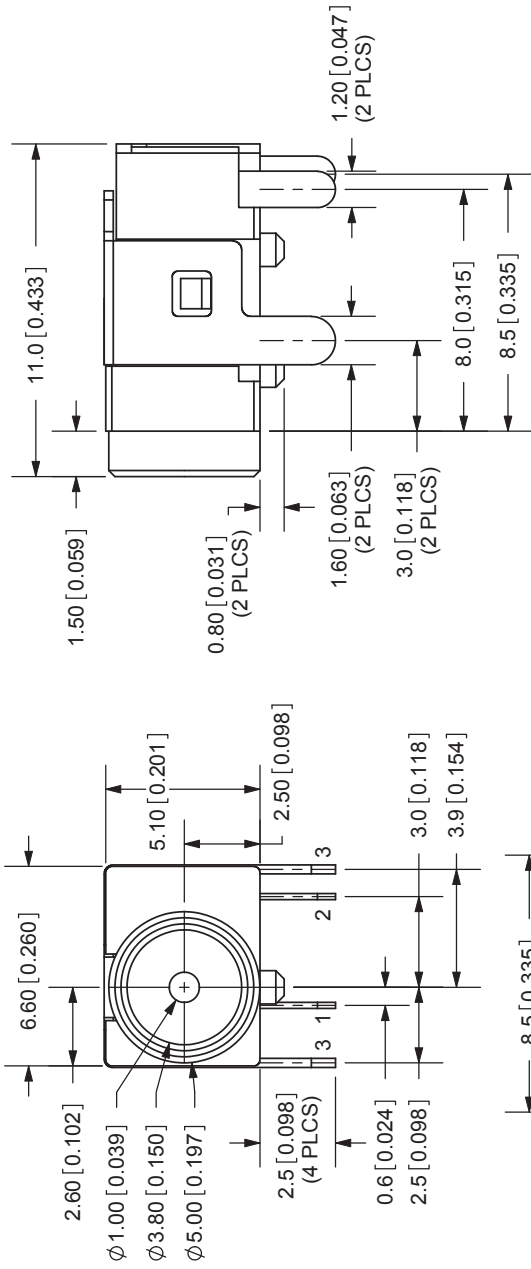
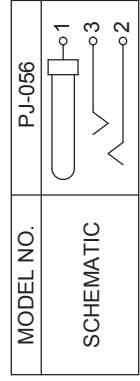

CENTER PIN DIAMETER 1.00mm Dia.

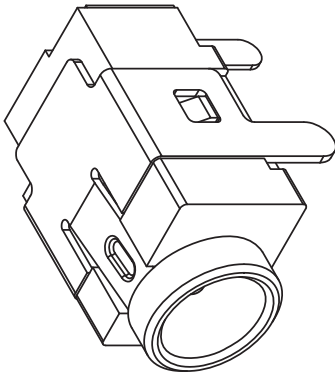

TOLERANCE:
X.X±0.2mm
X.XX±0.1mm
X.XXX±0.05mm



20050 SW 112th Ave.
Tualatin, OR 97062
Phone: 503-612-2300
800-275-4899
Fax: 503-612-2383
Website: www.cui.com

SPECIFICATIONS:
RATING: 16V DC @ 2A
CONTACT RESISTANCE: 50m OHMS MAX
INSULATION RESISTANCE: 100M OHMS MIN: 500V DC
VOLTAGE WITHSTAND: 500V AC R.M.S. FOR 1 MINUTE
LIFE: 5,000 CYCLES
OPERATING TEMP: -25° ~ +85°C

CENTER PIN	MATERIAL	PLATING
TERMINAL 1	Brass	Tin
TERMINAL 2	Brass	Tin
TERMINAL 3	Copper Alloy	Tin
BODY	Copper Alloy	Tin
	PA66	

TITLE:	DC POWER JACK	REV:	A
PART NO:	PJ-056	UNITS:	MM [INCHES]
DRAWN BY:	ZRJ	APPROVED BY:	
		SCALE:	4:1